



## GENERALIDADES

- Exclusivo diseño modular con lentes ópticos de policarbonato y cero pérdidas de luz. 8% más eficiente que productos similares.
- Diseñada para una óptima disipación de calor y reducción de peso.
- No emite radiación UV ni radiación IR.
- Ahorro de energía de un 65% en comparación con lámparas tradicionales.
- Protección contra picos de corriente, picos de voltaje, rayos, altas temperaturas, aumentando su vida útil.
- Vida útil de hasta 50.000 horas. Menor mantenimiento y remplazo.
- A prueba de agua y de polvo (IP 67).
- Piezas de acero inoxidable que mejoran su resistencia en ambientes corrosivos.
- Encendido y apagado rápido y sin parpadeo.
- Opera dentro de un amplio rango de voltaje.
- LEDs de alta eficiencia lumínica, con su tecnología de gel incorporada en sus lupas, y con un rendimiento estable.

## APLICACIONES

- Calles.
- Rutas.
- Estacionamientos.
- Sendas peatonales.
- Parques.

## PARÁMETROS TÉCNICOS

Datos eléctricos	
Potencia	70 W
Voltaje	100 – 240 V
Frecuencia	50 – 60 Hz
Factor de potencia	> 0,98
Distorsión armónica	< 10 %
Eficiencia energética	93 %

Datos lumínicos	
CCT	2.700 – 6.000 K
Lumens	13.300 lm
CRI	> 80
Eficiencia lumínica	190 lm/W
Ángulo de emisión	TIPO II v1 / TIPO II v2

Datos del producto	
Dimensiones	525x328x98mm
Peso	5.8 kg
Material de carcasa	Aluminio

Datos operativos	
Grado IP	67
Grado IK	10
Vida útil	50.000 h
Temperatura ambiente de trabajo	-40 °C a 50 °C
Número de productos en MCB de 16 A tipo B	(10)

Componentes	
Fuente	Meanwell
Protección contra sobretensión (10kVA)	Meanwell <b>(Opcional)</b>
Marca del chip LED	Samsung
Cantidad de chips LED	40 unidades
Compatible NEMA7 - DALI - 0 a 10v	<b>(Opcional)</b>

## DIMENSIONES

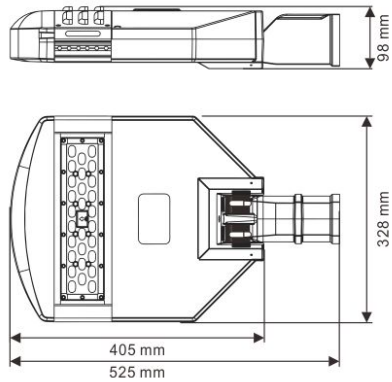

## CURVAS DE DISTRIBUCIÓN LUMÍNICA

TYPE II (Version 1)

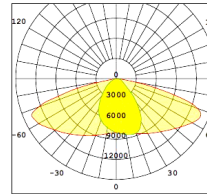

TYPE II (Version 2)

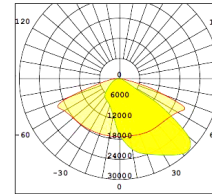

IS 15885 (Part 2/Sec13)



(for 12/12B/12DA/24/24B/24DA/36A/42/42A/48A/54 only)

